

ELM-Serie / BUILT IN

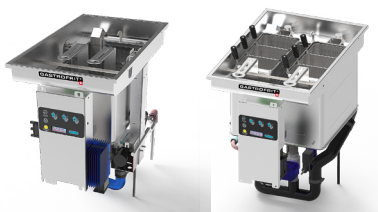

F-Serie / BUILT IN



TW-Serie / BUILT IN

Operating instructions BUILT IN

FRYERS / PASTACOOKERS

Built-in electronic or electro-mechanical controls

English

Version 8.7

Thank you for choosing a Gastrofrit® product. Your product was entirely made in Switzerland. Your product has been subjected to a long-term test. Please note that the performance fluctuations, safeguards and frequency ranges 50 Hertz or 60 Hertz differ in individual countries. Before commissioning, check the exact requirements for carefree operation of the device.

Installation, connection and commissioning of the control may only be carried out by persons trained by Gastrofrit.

3	Modelle und Varianten
3	Power connection / technology
3	Electricity
3	Installation of the heating basin (normal case)
3	Installation of heating basin (additional parts)
3	Assembly instructions lift motor
6	Pastacooker error catalog
7	Fault catalog deep fryers
8	Installation description of the fitting box with pan
8	Fittingbox
8	Installation situation / components
9	Installation of display box
10	Mounting the bracket on the built-in stove
13	Customer service, maintenance
14	Built in drawings:

Models and variants

ELM-300 built in	Item No. 101135
ELM-400 built in	Item No. 101145
ELM2-400 built in	Item No. 101146
ELM2-500 built in	Item No. 101251
F-300 built in	Item No. 100130
F-400 built in	Item No. 101145
F2-400 built in	Item No. 102240
F2-500 built in	Item No. 100251
TW-350 built in	Item No. 110135
TW-400 built in	Item No. 110140

Power connection / technology

Please note that the power fluctuations, safeguards and frequency ranges 50 Hertz or 60 Hertz differ in individual countries. Before commissioning, check the exact requirements for carefree operation of the device.

The electricity connection may only be provided by trained qualified personnel can be connected. According to the requirements stipulated in the country.

- After switching on the main switch, the device starts and lights up in the ON / OFF LED.
- The 3x400V (3L + N + PE) power connection is made with a standard-compliant CE plug.

Electricity

Danger: Use silicone braids for the main connection of the devices. To guarantee trouble-free operation:

- The specifications regarding cable cross-section and fuse protection must be strictly observed. No other devices or power consumers may be connected to the fuse protection of the supply line. The devices were tested for their EMC compatibility. The test reports can be viewed at Gastrofrit.
- You need to make sure that no cables or conduits are pinched.

Design of the area around the collection container:

The base for the collecting container should consist of low-wear, easy-to-clean material. It is important to ensure that the container can be removed quickly for easy cleaning. The container should also be guided to the side and have a defined end position.

1. Protection against accidental contact must be provided during installation.
2. The devices must not be built into flammable material.
3. If the device is installed next to a large heat source, sufficient ventilation of the control box must be ensured. (maximum temperature of the

control box 70 ° C)

4. Wird das Gerät neben einer großen Hitzequelle eingebaut, ist auf eine genügende Lüftung des Steuerkastens zu achten. (maximale Temperatur des Steuerkastens 70°C)

Installation of the heating basin (normal case)

Inlay and silicone seal

The heating basin is placed in the corresponding opening, the joint must be sealed with silicone. The holes provided for frame assembly can be closed with blind rivets or screws. The silicone joint must be checked regularly for leaks in order to avoid the ingress of liquids in the long term.

Installation of heating basin (additional parts)

With frame parts or upstand kitchen cover The heating basin can also be attached to the table with frame parts. The frame parts should be around 20mm shorter than the outside dimensions of the pool. When installing in a metal cover, this can also be folded up analogously to the frame part. The frame parts are not part of the Gastrofrit delivery. For the installation of the frame parts, the opening must be 2mm larger. The joint still has to be sealed with silicone. The frame parts are bent from 1.5mm stainless sheet metal and screwed to the table and basin.

Assembly instructions lift motor

Please make sure that you have connected the power plug correctly if it was not installed by Gastrofrit AG. The earth (color: yellow / green, symbol 0) and the neutral wire (color blue, symbol N) are marked in the connector housing, connect the phases so that the brown wire is in the middle of the two black wires. Electrical connection of the lifting motor
The connection cable contains the following 4 strands:

- yellow/green ground wire
- blue neutral conductor
- brown Phase lift motor up
- black Phase lift motor down

When you are standing in front of the device and have tilted the cover towards you, you can connect the strands as follows:

Please connect the earth to the metallic (gold-colored) earth connection. The neutral conductor to the blue clamp, the brown phase to the left gray clamp, the

black phase to the right gray clamp.clamp.

Mechanical attachment of the lifting motor

The underside of the plate on which the lifting motor rests must be cleaned of dirt, oil splashes, insulation and other objects

1. Please extend the lifting rod (neutral conductor and brown phase).
2. Turn the bushing away from the square tube with a 24 mm open-ended spanner.
3. Now you can push the lifting rod through the hole in the pan from below. Make sure that the offset in the square tube protrudes against the pan. The washer with the rounding must be placed on the underside of

the sheet.

4. If you now push the bushing over the lifting rod, you can screw everything together.

ATTENTION: The bushing only needs to be tightened slightly so that the lifting motor is fixed in position. Please do not forget to coat the thread with Loctide 270 or an equivalent screw locking agent.

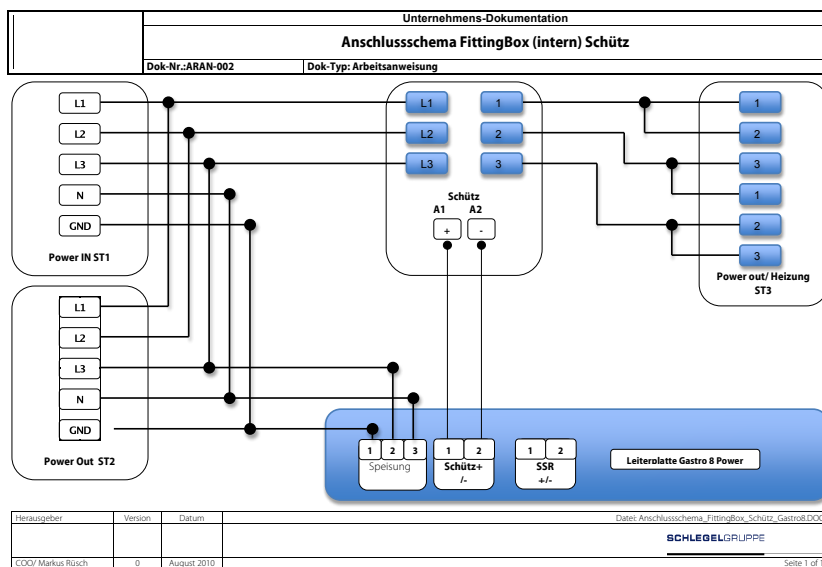

Unternehmens-Dokumentation

Anschlusschema FittingBox (intern) SSR

Dok-Nr.: ARAN-001 Dok-Typ: Arbeitsanweisung

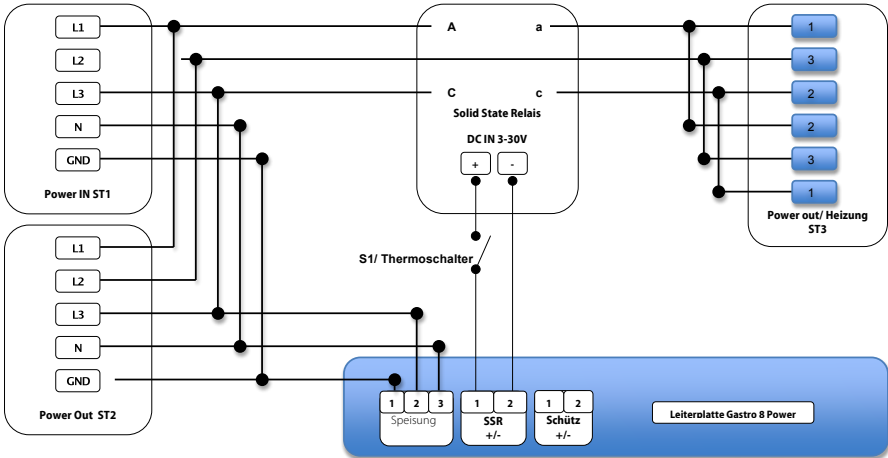

Herausgeber	Version	Datum	Datei: Anschlusschema_FittingBox_SSR_Gastro8.DOC
			SCHLEBELGRUPPE
COO/ Markus Rüschi	0	August 2010	Seite 1 of 1

Unternehmens-Dokumentation

Anschlusschema FittingBox (intern) SSR für Energieoptimierung

Dok-Nr.: ARAN-001-1 Dok-Typ: Arbeitsanweisung

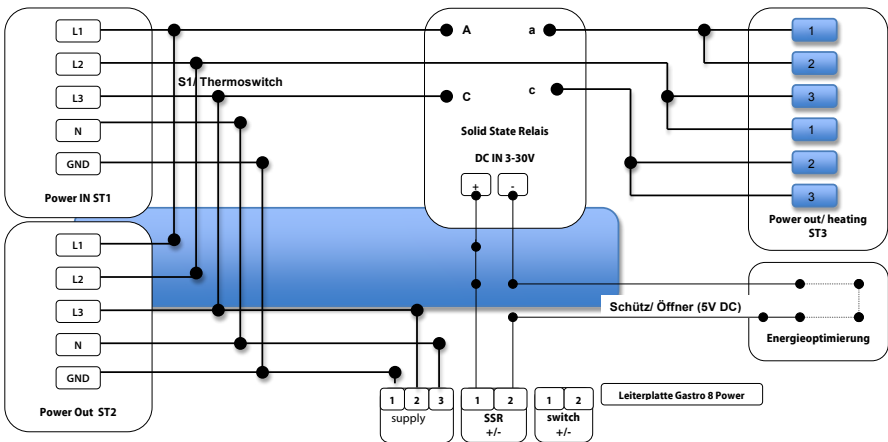

Herausgeber	Version	Datum	Datei: Anschlusschema_FittingBox_SSR_Gastro8_Energieopt.doc
			SCHLEBELGRUPPE
COO/ Markus Rüschi	0	August 2010	Seite 1 of 1

Pastacooker error catalog

	Error description / display	How to fix	Remarks
1	Error 1 Call up the PT 100 menu Note the display	Check PT-1000 connection If, ok, then measure the PT-1000 ohmic value	OK = about 108 ohms / 20 ° C NOK = 0 ohms or infinite
2	Machine heats up through unregulated	Check contactor Check software version Perform a CPU reset Reset limiter button	Contactor sticks, contactor has to be checked and possibly replaced
3	conventional machine heats through unregulated	Check thermostat check contactor	Thermostat misadjusted and not adjusted
4	The machine only heats when the red heating pulse switch is pressed	Replace heating limit switch	Can` t always be replaced must be bridged
5	No indication on the display	De-energize the device Electronics defective	Change control
6	Residual current switch / fuse blows out	The heater has a short circuit Check wiring burnt heater plug Phase – Phase oder Phase-0-wire short circuit SSR/ Triac has short circuit	
7	Conventional machine, power switch green does not ligh up	Press the limiter button or replace.	
8	Lift motors only run halfway up/down	Replace capacitor 33µF/ 270V clean the lift motor	
9	Lift motors are moving in the wrong direction	Capacitors 33µF/ 270V double mounted. Check cable connection of hoist motor (phases reversed)	Capacitor value cancels corresponds to the value if no capacitor is installed
10	No water supply	Check solenoid valve	Solenoid valve cold water up to 50°C Solenoid valve hot water up to 100°C
11	Machine leaking	Check PT-1000 seal Check drain system Check water supply	

Fault catalog deep fryers

	Error description / display	How to fix	Remarks
1	Error 1 PT-1000 Call up the PT 1000 menu Note the display	Check PT-1000 connection If ok, then measure the PT-1000 ohmic value	OK = about 108 Ohms/ 20°C NOK = 0 Ohms or infinite
2	Machine heats up through unregulated	Check contactor Check software version Perform CPU reset Reset limiter button	Contactor sticks, contactor must be controlled and may need to be changed
3	Conventional machine heats through unregulated	Check thermostat Check contactor	Thermostat mostly adjusted
4	The machine only heats when the red heating pulse switch is pressed	Replace heating limit switch	Cannot always be replaced it has to be bridged
5	No indication on the display	De-energize the device Elektronics defective	Change control
6	Residual current switch / fuse blows out	The heater has a short circuit Check wiring Burnt heater plug Phase – Phase oder Phase- 0-conductor short circuit SSR/ Triac has short circuit	
7	Conventional machine, power switch green does not light up	Press or replace the limiter button.	
8	Lift motors only run halfway up / down	Replace capacitor 33µF/ 270V. Clean the lift motor	
9	Lift motors are moving in the wrong direction	Capacitors 33µF/ 270V double assembled Check lift motor cable connection (phase twisted)	Capacitor value cancels out, corresponds to the value if no capacitor is installed
10	Device control does not work.	Device back to the factory modification membrane keyboard	Revision
11	Pump works, but no oil delivery, hose or pump blocked	Clean with wire	
12	Pump does not work	Measure voltage at socket Pump at normal 230V socket plug in and check	Pump voltage = 230V
13	Machine leaking	Replace O-ring Check PT-1000 seal Check oil check seal Check ball valve	

Installation description of the fitting box with pan

Fittingbox

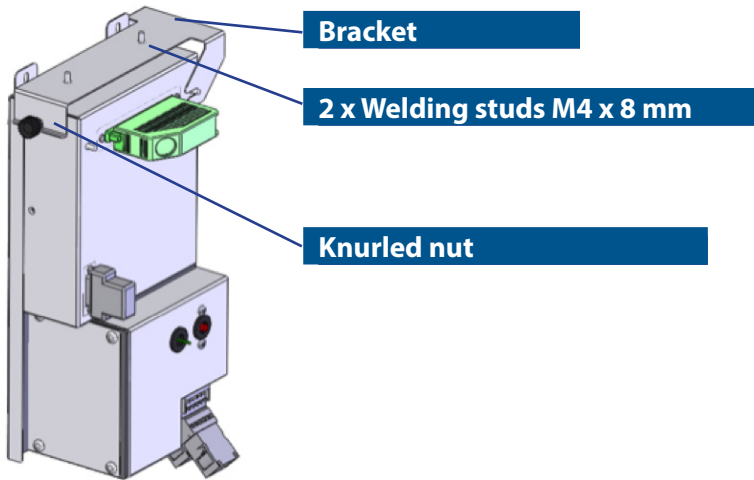

Installation situation / components

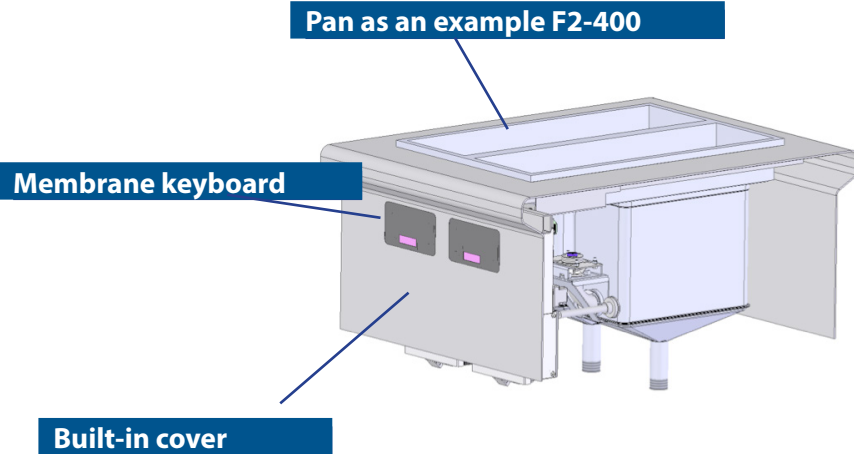

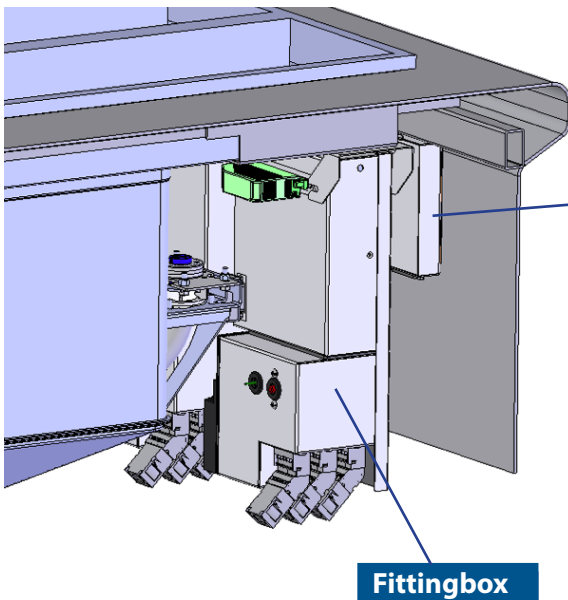

Installation of display box

1. 4 x Position Welko M4-8 mm symmetrically to the cut.
2. Rectangle dimensions:

Height	91 mm
Width	144 mm

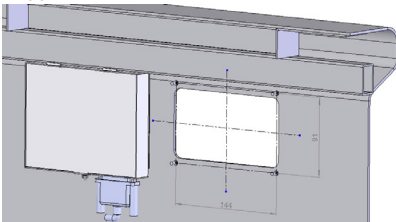

3. Assembly seal
Apply seal

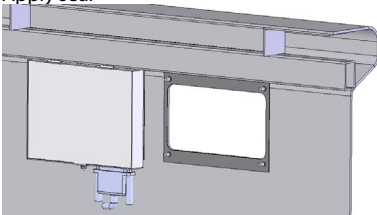

4. Assembly Display
 Assembly of the display box
 4x hexagon nut M4

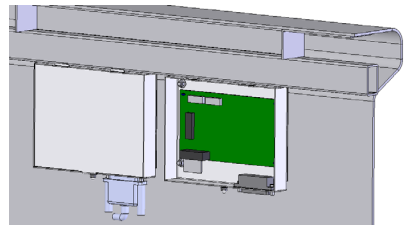

5. close the lid
 Tighten with a hexagon nut M3 with flange and serrated lockwasher

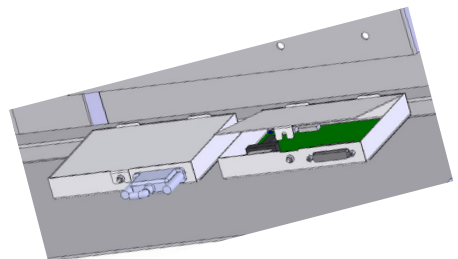

- 6.

Sheet metal for fastening the bracket

2 x holes $\varnothing = 8 \text{ mm}$

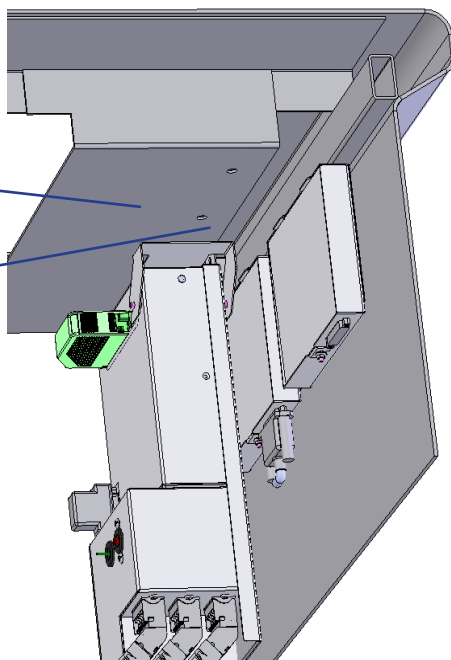

Dimensioning

- Lower edge: panel cover to cover, 64.5 mm
- Inner surface: fix the cover to the center of the bracket, 87 mm

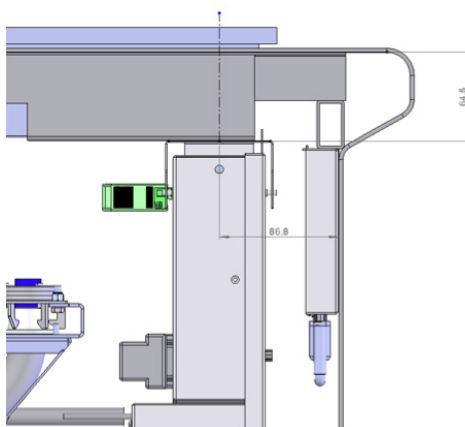

Holes

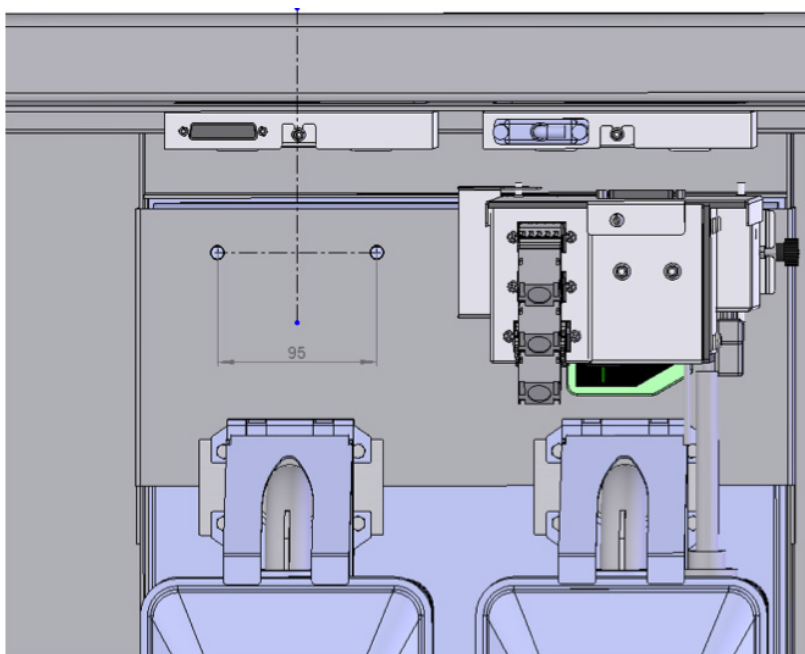

Position the hole = 0.8 mm symmetrically to the display box

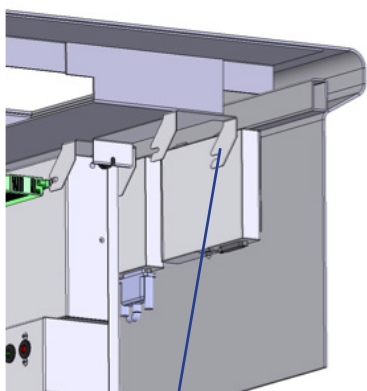

Bracket

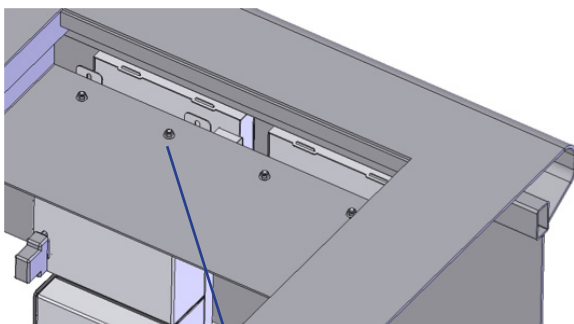

Hexagon nut M4

Hang in the fitting box

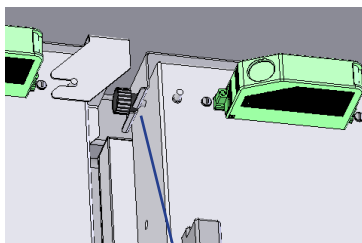
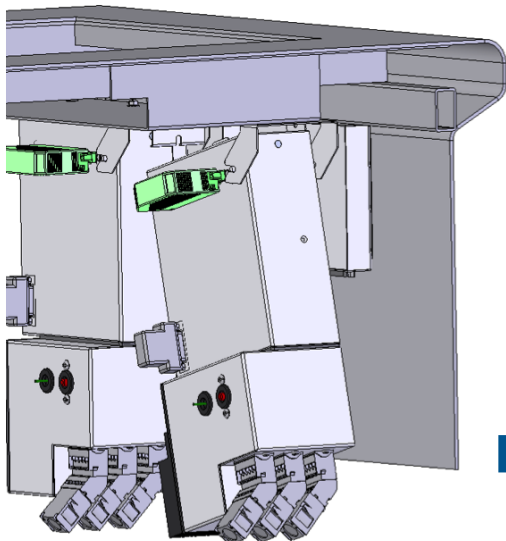

Tighten the knurled nut

Installation dimensions pans / basins

Type	Width in mm	Depth in mm	max. radius in mm
F-200	180	580	3
F-300	280	580	3
F-400	380	580	3
F2-400	780	580	3
TW-300	280	580	3
TW-350		580	3
TW-400	780	580	3

The heating basins are placed in the corresponding opening, the joint must be sealed with silicone. The holes provided for frame assembly can be closed with blind rivets or screws.

The silicone joint must be checked regularly for leaks in order to avoid the ingress of liquids in the long term.

Customer service, maintenance

In the event of operational disruptions, contact

GASTROFRIT AG in Rorschach

Tel. +41718558070 or email: info@gastrofrit.ch.

The device may only be repaired and connected by trained specialists.

Note (only for repair service with Gastrofrit training). Before you fold the cover forwards, the door must be opened! Attention! All mains circuits must be switched off before access to the connection terminals.

Important:

With every report to the service point, please state the type and number of the device (inside of the door). It is recommended to enter the type and number below. Regular maintenance can extend the life of your device. With a service and maintenance contract, you can instruct the manufacturer to check your device every six months.

You can find more detailed information on the service contracts at

GASTROFRIT AG in Rorschach

Tel. +41718558070 or Email: info@gastrofrit.ch.

to fill in yourself:

Datum: _____

Typ: _____

SerieNr: _____

Spannung: _____

mit Ölcheck

mit Hubtechnik

mit Ölfiltrieranlage

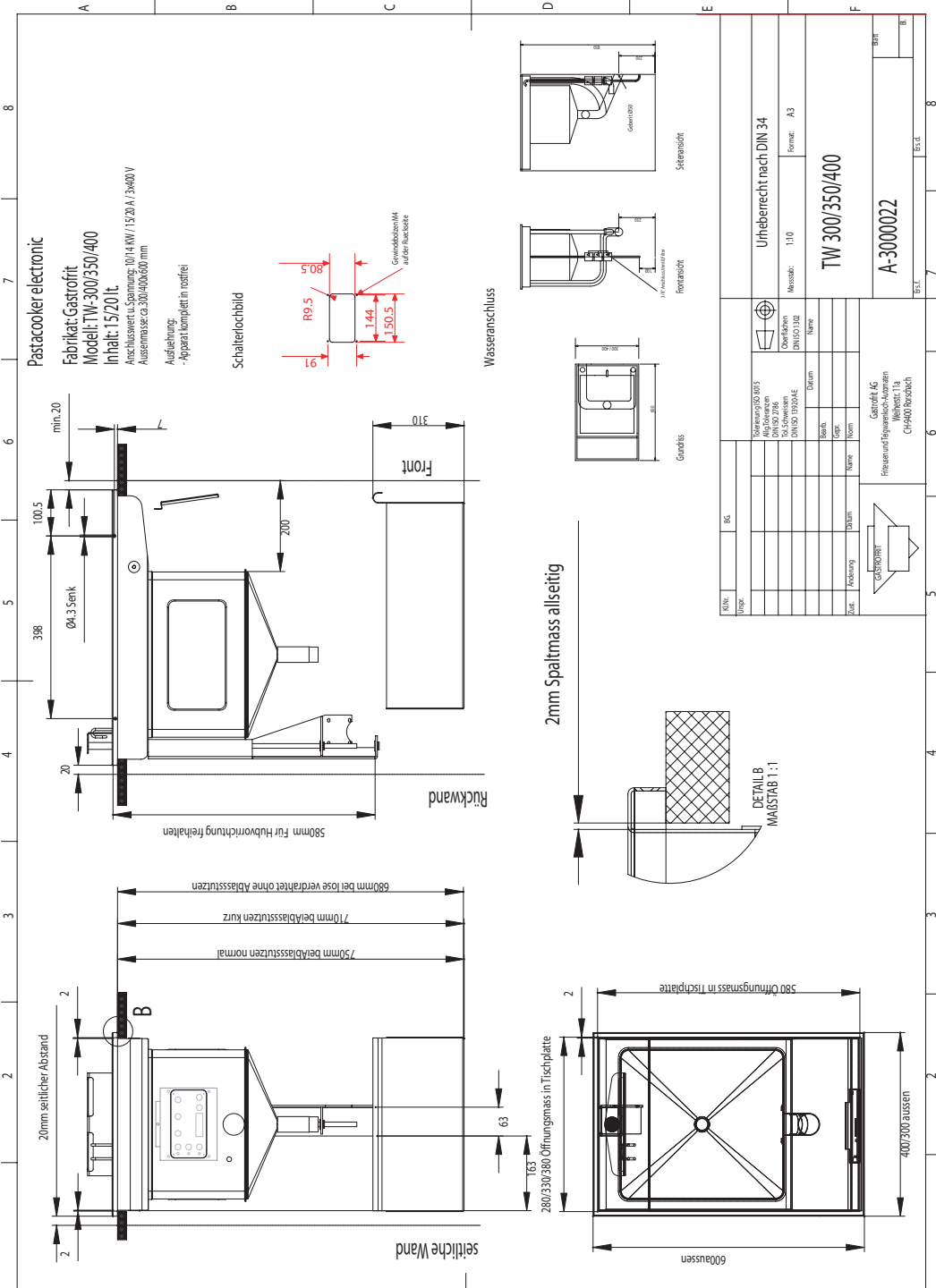

Diese Zeichnung ist unser geistiges Eigentum. Sie darf ohne unsere schriftliche Zustimmung nicht kopiert, reproduziert, weitergegeben werden.
 This representation is our intellectual property. You may not use or reproduce it without our written consent or all rights reserved.
 Questo disegno è nostra proprietà intellettuale. È vietata la ristampa o l'uso non autorizzato senza il nostro permesso scritto.
 This drawing is our intellectual property. You may not use or reproduce it without our written consent or all rights reserved.

Ausschnitt für Tischplatte

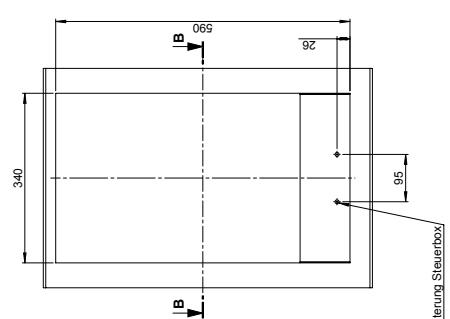

SCHNITT B-B

Ausschnitt für Display

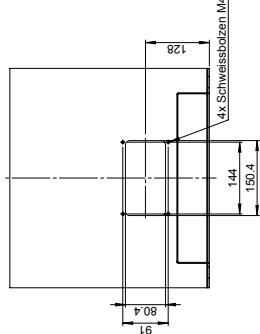

Ansicht ohne Bespieblende

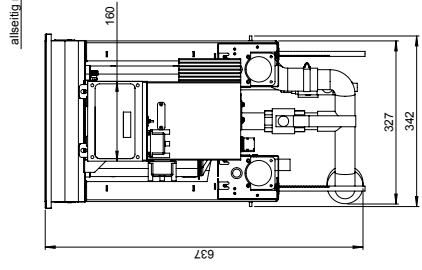

SCHNITT A-A

Halterung Steuerbox

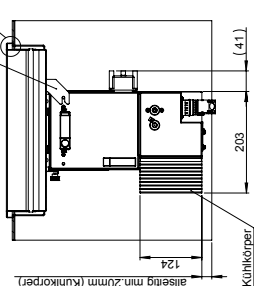

ANSICHT C

MAßSTAB: 1 : 1

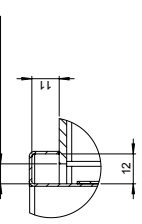

40mm für Einbau Steuerbox laut Zeichnung.

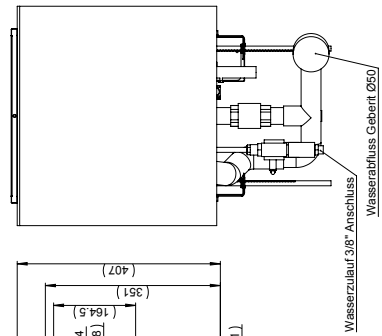

2xØ8mm für Halterung Steuerbox.

alle Angaben ohne Gewähr.
technische Änderungen vorbehalten

 Material: Dimension:		Material: Dimension:	
Max. B Max. S Max. L Max. H Max. T Max. D	Name Art. N. Art. L. Art. S. Art. T. Art. D.	Benennung TW-350 Zählrohr: BG Einbau-16023012	Maßstab: 1:5 Formel: A2 Blatt: 001/06

This representation is our intellectual property. The use without written consent as a photocopy or for the manufacture of the work or for its introduction is prohibited.
 Diese Darstellung ist unser geistiges Eigentum. Die Vervielfältigung ohne schriftliche Zustimmung oder Reproduktion nach der Artfertigung des Werkes, das Nachahmung oder die Einführung in den Verkehr ist untersagt.
 This representation is our intellectual property. The use without written consent as a photocopy or for the manufacture of the work or for its introduction is prohibited.
 Diese Darstellung ist unser geistiges Eigentum. Die Vervielfältigung ohne schriftliche Zustimmung oder Reproduktion nach der Artfertigung des Werkes, das Nachahmung oder die Einführung in den Verkehr ist untersagt.

Ansicht ohne Beispieltende

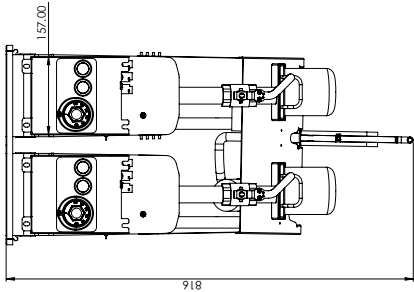

allseitig min. 20mm

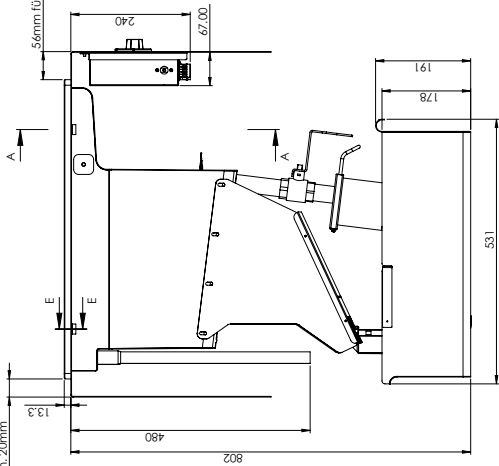

Ausschnitt für Tischplatte

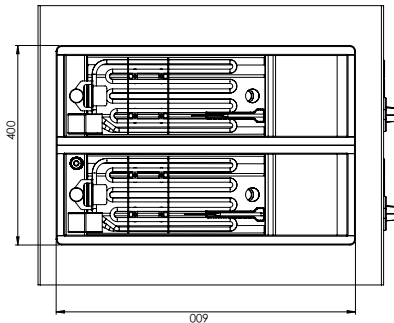
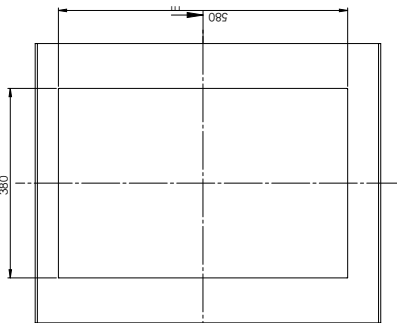

SCHNITT A-A

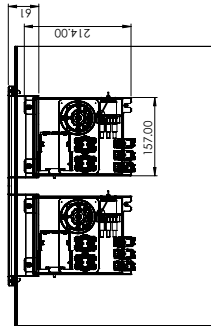

Ausschnitt für Display

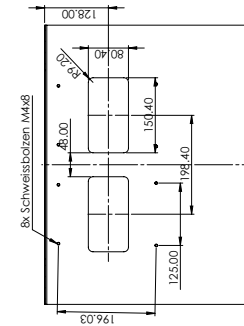

SCHNITT E-E

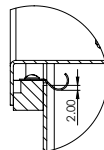

DETAIL F

MAßSTAB 1 : 1

alle Angaben ohne Gewähr
 technische Änderungen vorbehalten

 Bedienungsanleitung Material: ELM2-400 Gewicht:		Material: ELM2-400 Gewicht:	
Dimension: L5 Formel: A2 Zeichnung: 017.01		Zeichnung: 017.01 Zeichnungs-Nr.: 80 Einbaugeräte Gezeichnet von: ... Geprüft von: ...	

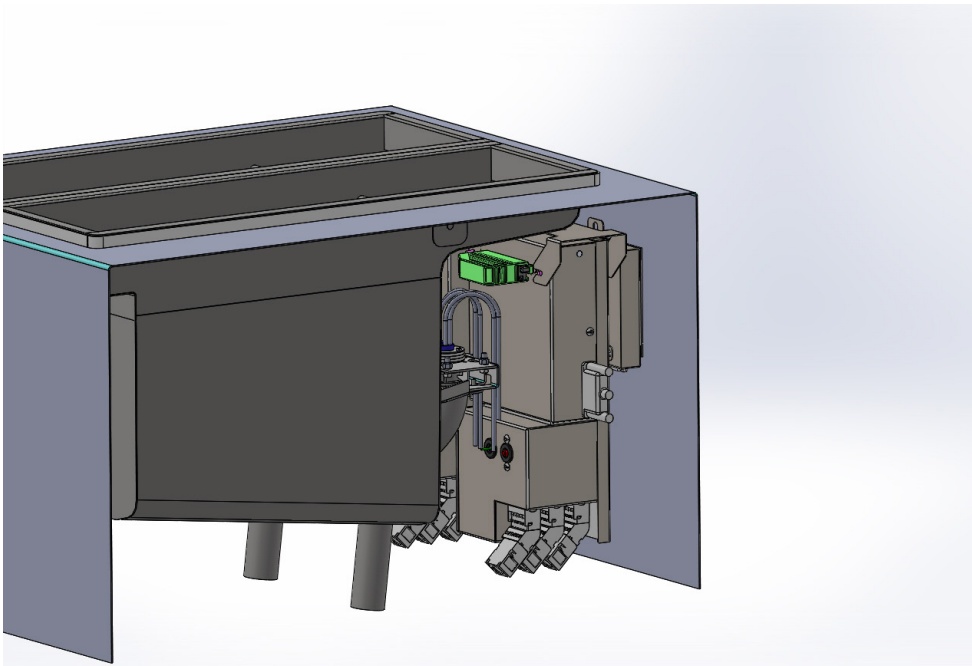
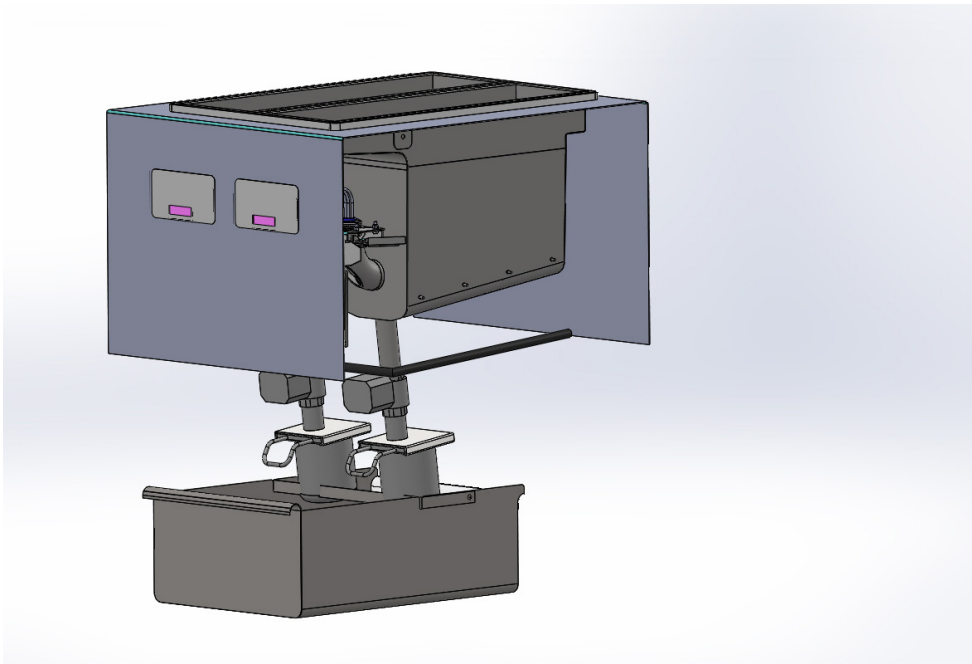

Ansicht ohne Bespielblende

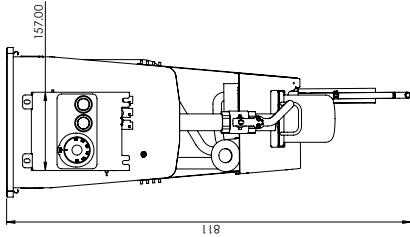

einseitig min. 20mm

56mm für Einbau Steuerbox laut Zeichnung

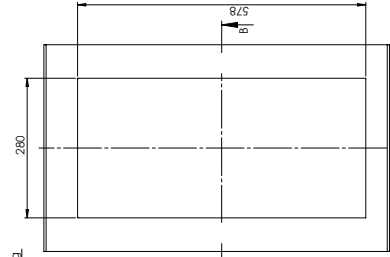

Ausschnitt für Tischplatte

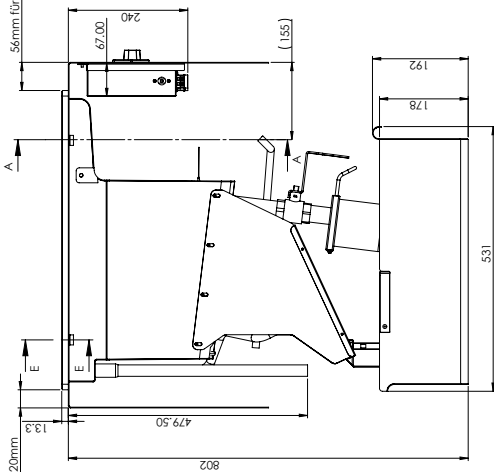
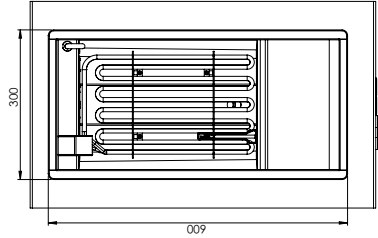

SCHNITT B-B

Ausschnitt für Display

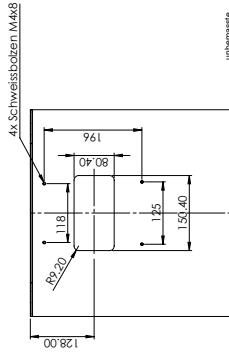

4x Schweißboizen M4x8

unbenutzte
Bohrungen
DIN ISO 13715
1.45 1.42 1.45
1.43 1.45

SCHNITT A-A

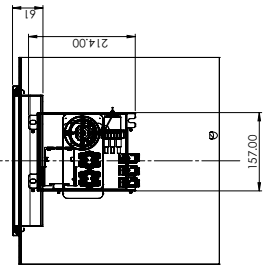

SCHNITT E-E

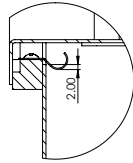

DETAIL F

MAßSTAB 1 : 1

**Alle Angaben ohne Gewähr
technische Änderungen vorbehalten**

Skizzennummer :
Dokumentation :

Material :
Gewicht :

Umsatz : 15
Formel : A2

ELM-300

Zustellung : Bis Einbaugerät

01/10

This representation is our intellectual property. The use without written consent at all other places is prohibited. The manufacturer of the work or of its reproduction is liable. Gastrofrit AG, Mammetswilstrasse 11, CH-7400 Solothurn. This representation is our intellectual property. The use without written consent at all other places is prohibited. The manufacturer of the work or of its reproduction is liable. Gastrofrit AG, Mammetswilstrasse 11, CH-7400 Solothurn.

Ausschnitt für Tischplatte

einseitig min. 20mm
56mm für Einbau Steuerbox laut Zeichnung

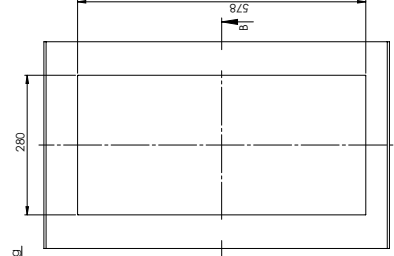

Ansicht ohne Bespielblende

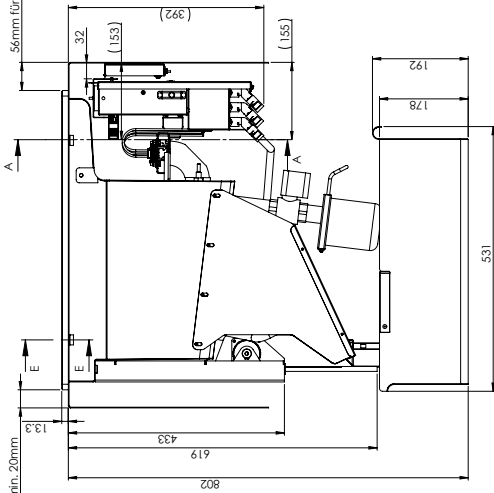
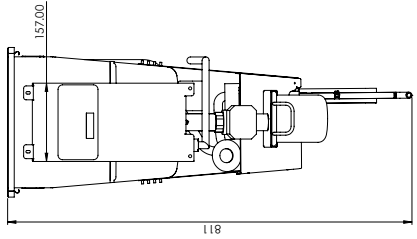

**SCHNITT B-B
Ausschnitt für Display**

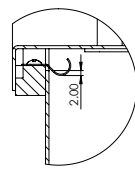
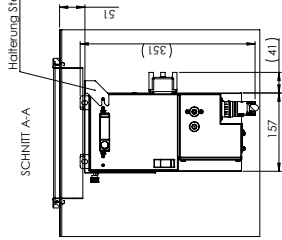
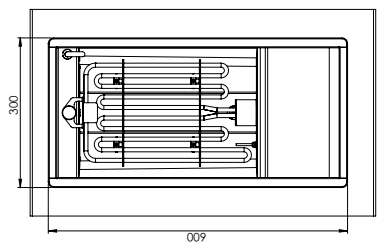
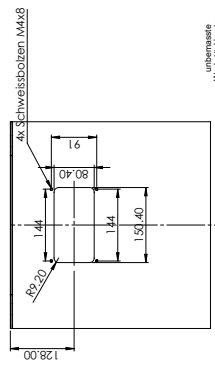

**Alle Angaben ohne Gewähr
Technische Änderungen vorbehalten**

Material		Gewichte	
Material	Umsatz	Material	Umsatz
F-300	1.5	F-300	1.5
Formel:	A2	Formel:	A2
Blatt:	01/101	Blatt:	01/101
Zustimmung:		Zustimmung:	
Gezeichnet:		Gezeichnet:	
Geprüft:		Geprüft:	
Freigegeben:		Freigegeben:	
Zustimmung:		Zustimmung:	
Gezeichnet:		Gezeichnet:	
Geprüft:		Geprüft:	
Freigegeben:		Freigegeben:	

DETAIL F
MAßSTAB 1 : 1

unbenutzte
Werte
DIN ISO 13715
1.45
1.42
1.45
1.42

This representation is for informational purposes only and does not constitute a contract. The manufacturer is not responsible for any damage or loss of data. The manufacturer is not responsible for any damage or loss of data. The manufacturer is not responsible for any damage or loss of data.

Ansicht ohne Beispielenblende

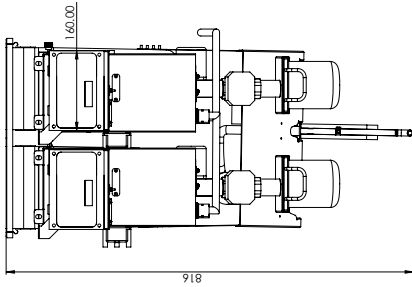

distanzstab min. 20mm

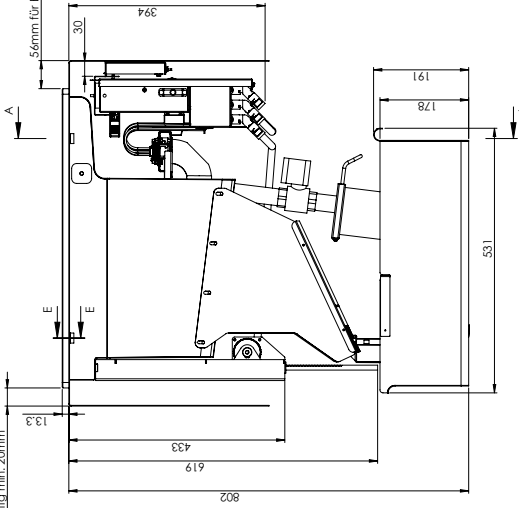

Ausschnitt für Tischplatte

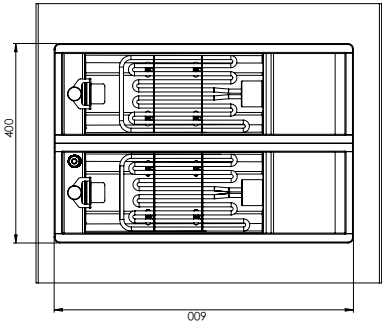
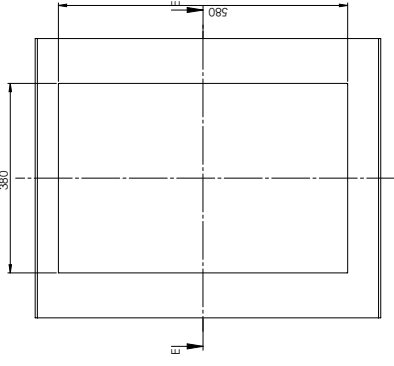

Ausschnitt für Display & Schweißboizen M4x8

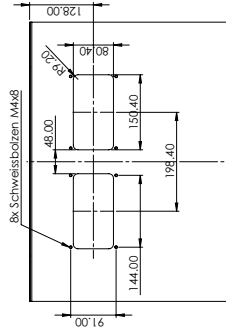

SCHNITT E E



SCHNITT A-A
Halterung Steuerbox

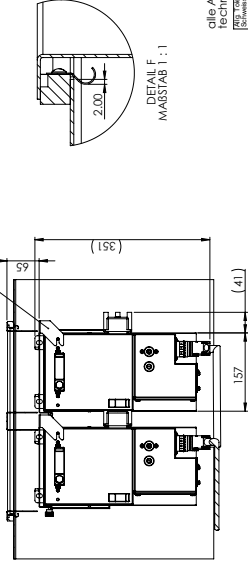

DETAIL F
MAßSTAB 1 : 1

alle Angaben ohne Gewähr
technische Änderungen vorbehalten

Bezeichnung	F2.400 V2		Zusatz Nr.	01701
Umsatz	E5		Formel	A2
Material			AGNR	
Dokumentation	Zeichnung	Material	Stanzung	Bearbeitung
	AKZ A	AKZ B	AKZ C	AKZ D
	AKZ E	AKZ F	AKZ G	AKZ H
	AKZ I	AKZ J	AKZ K	AKZ L
	AKZ M	AKZ N	AKZ O	AKZ P
	AKZ Q	AKZ R	AKZ S	AKZ T
Produktions-Status	GASTROFRIT			
Herstellung	1999/2007	1999/2007	1999/2007	1999/2007
Gezeichnet	G		Geprüft	PO

**EU/UE KONFORMITÄTSERKLÄRUNG
DECLARATION OF CONFORMITY
DÉCLARATION DE CONFORMITÉ**www.gastrofrit.chinfo@gastrofrit.ch

Tel.: +41 71 855 80 70

Wir
We
Nous

(Name des Anbieters) (supplier's name) (nom du fournisseur)

GASTROFRIT AG, Weiherstrasse 11, CH-9400 Rorschach

(Anschrift) (address) (adresse)

erklären in alleiniger Verantwortung, dass das Produkt
declare under our sole responsibility that the product
déclarons sous notre seule responsabilité que le produit**Gastrofrit Fritteusen****ELM-300 / ELM-400 / ELM2-400 / ELM2-500**(Bezeichnung Typ oder Modell), Los-, Chargen- oder Seriennummer, möglichst Herkunft und Stückzahl)
(title and/or number and date of issue of the standard(s) or other normative document(s))
(titre et/ou no. et date de publication de la (des) norme(s) ou autre(s) document(s) normatif(s))auf das sich diese Erklärung bezieht, mit der/den folgenden Norm(en) oder normativen
Document(en) übereinstimmt.to which this declaration relates is in conformity with the following standard(s) or other
normative document(s)auquel se réfère cette déclaration est conforme à la (aux) norme(s) ou autre(s) document(s)
normatif(s)**IEC 60335-1: 2010;****IEC 60335-2-37: 2002+ Cor.: 2007+ A1:2008+ A11: 2012****IEC 60335-2-47: 2012;****EN 55014-1: 2006+A1:09+A2: 11;****EN 55014-2: 1997+A1:01+A2:08;****EN 61000-3-2: 2006+A1: 09+A2: 09****EN 61000-3-3: 2013**(Titel und/oder Nummer sowie Ausgabedatum der Norm(en) oder der anderen normativen Dokumente)
(title and/or number and date of issue of the standard(s) or other normative document(s))
(titre et/ou no et date de publication de la (des) norme(s) document(s) normatif(s))

Gemäss den Bestimmungen der Richtlinie(n);

Following the provisions of Directive(s);

Conformément aux dispositions de(s) Directive(s)

(falls zutreffend) (if applicable) (le cas échéant)

Richtlinie 2006/95/CE; Richtlinie 2006/42/CE; Richtlinie 2004/108/CE(Ort und Datum der Ausstellung)
(Place and date of issue)
(Lieu et date)

Rorschach, 01.01.2021

(Name und Unterschrift oder gleichwertige
Kennzeichnung des Befugten)
(name and signature or equivalent marking of
authorized person)
(nom et signature du signataire autorisé)Alexander Schlegel
Geschäftsführer

**EU/UE KONFORMITÄTSERKLÄRUNG
DECLARATION OF CONFORMITY
DÉCLARATION DE CONFORMITÉ**

www.gastrofrit.ch
info@gastrofrit.ch
Tel.: +41 71 855 80 70

Wir
We
Nous

(Name des Anbieters) (supplier's name) (nom du fournisseur)

GASTROFRIT AG, Weiherstrasse 11, CH-9400 Rorschach

(Anschrift) (address) (adresse)

erklären in alleiniger Verantwortung, dass das Produkt
declare under our sole responsibility that the product
déclarons sous notre seule responsabilité que le produit

Gastrofrit Fritteusen

F-300 / F-400 / F2-400 / F2-500

(Bezeichnung Typ oder Modell), Los-, Chargen- oder Seriennummer, möglichst Herkunft und Stückzahl)
(title and/or number and date of issue of the standard(s) or other normative document(s))
(titre et/ou no. et date de publication de la (des) norme(s) ou autre(s) document(s) normatif(s))

auf das sich diese Erklärung bezieht, mit der/den folgenden Norm(en) oder normativen
Dokument(en) übereinstimmt.

to which this declaration relates is in conformity with the following standard(s) or other
normative document(s)

auquel se réfère cette déclaration est conforme à la (aux) norme(s) ou autre(s) document(s)
normatif(s)

IEC 60335-1: 2010;

EN 55014-1: 2006+A1:09+A2: 11;

IEC 60335-2-37: 2002+ Cor.: 2007+ A1:2008+ A11: 2012

EN 55014-2: 1997+A1:01+A2:08;

IEC 60335-2-47: 2012;

EN 61000-3-2: 2006+A1: 09+A2: 09

EN 61000-3-3: 2013

(Titel und/oder Nummer sowie Ausgabedatum der Norm(en) oder der anderen normativen Dokumente)
(title and/or number and date of issue of the standard(s) or other normative document(s))
(titre et/ou no et date de publication de la (des) norme(s) document(s) normatif(s))

Gemäss den Bestimmungen der Richtlinie(n);

Following the provisions of Directive(s);

Conformément aux dispositions de(s) Directive(s)

(falls zutreffend) (if applicable) (le cas échéant)

Richtlinie 2006/95/CE; Richtlinie 2006/42/CE; Richtlinie 2004/108/CE

(Ort und Datum der Ausstellung)
(Place and date of issue)
(Lieu et date)

Rorschach, 01.01.2021

(Name und Unterschrift oder gleichwertige
Kennzeichnung des Befugten)
(name and signature or equivalent marking of
authorized person)
(nom et signature du signataire autorisé)



Alexander Schlegel
Geschäftsführer

**EU/UE KONFORMITÄTSERKLÄRUNG
DECLARATION OF CONFORMITY
DÉCLARATION DE CONFORMITÉ**

www.gastrofrit.ch
info@gastrofrit.ch
Tel.: +41 71 855 80 70

Wir
We
Nous

(Name des Anbieters) (supplier's name) (nom du fournisseur)

GASTROFRIT AG, Weiherstrasse 11, CH-9400 Rorschach

(Anschrift) (address) (adresse)

erklären in alleiniger Verantwortung, dass das Produkt
declare under our sole responsibility that the product
déclarons sous notre seule responsabilité que le produit

Gastrofrit Pastacooker

TW-350 / TW-400

(Bezeichnung Typ oder Modell), Los-, Chargen- oder Seriennummer, möglichst Herkunft und Stückzahl)
(title and/or number and date of issue of the standard(s) or other normative document(s))
(titre et/ou no. et date de publication de la (des) norme(s) ou autre(s) document(s) normatif(s))

auf das sich diese Erklärung bezieht, mit der/den folgenden Norm(en) oder normativen
Dokument(en) übereinstimmt.
to which this declaration relates is in conformity with the following standard(s) or other
normative document(s)
auquel se réfère cette déclaration est conforme à la (aux) norme(s) ou autre(s) document(s)
normatif(s)

IEC 60335-1: 2010; EN 55014-1:2006+A1:09+A2:11; EN 61000-3-2: 2006+A1:09+A2:09
IEC 60335-2-15: 2012; EN 55014-2:1997+A1:01+A2:08; EN 61000-3-3: 2013
IEC 60335-2-47: 2012;

(Titel und/oder Nummer sowie Ausgabedatum der Norm(en) oder der anderen normativen Dokumente)
(title and/or number and date of issue of the standard(s) or other normative document(s))
(titre et/ou no et date de publication de la (des) norme(s) document(s) normatif(s))

Gemäss den Bestimmungen der Richtlinie(n);
Following the provisions of Directive(s);
Conformément aux dispositions de(s) Directive(s)
(falls zutreffend) (if applicable) (le cas échéant)

Richtlinie 2006/95/CE; Richtlinie 2006/42/CE; Richtlinie 2004/108/CE

(Ort und Datum der Ausstellung)
(Place and date of issue)
(Lieu et date)

Rorschach, 01.01.2021

(Name und Unterschrift oder gleichwertige
Kennzeichnung des Befugten)
(name and signature or equivalent marking of
authorized person)
(nom et signature du signataire autorisé)



Alexander Schlegel
Geschäftsführer